



MATTIAZZI

ITALY

115



MATTIAZZI
ITALY



MATTIAZZI: HANDMADE WITH ROBOTS

When Nevio and Fabiano Mattiazzi were teenagers in the late 1960s, the brothers worked at their uncle's wood factory, located in an area of northeast Italy affectionately known as the 'the chair triangle.' The young men, captivated by the expansive properties of the material, developed an obsession and before long they wanted to run their own company. Setting to work to achieve this goal, they built their own workshop brick by brick and by 1979, their dream became reality with the formal launch of Mattiazzi.

Today, Mattiazzi remains rooted in this humble heritage and the traditions of handcrafted wooden chairs, but it has also evolved into a technologically advanced and ecologically aware company fit for the 21st century. They are now internationally renowned for the ethical and conscious industrial production of premium wooden furnishings conceived by some of the world's foremost designers, all while remaining a family-run company with a staff of only 30—a relatively small size that grants the company many advantages, including the ability to remain agile, respond quickly to changes, and be more experimental.

For the first few years after opening their workshop, Nevio and Fabiano worked alone, continuing to handmake chairs for other companies. But as Mattiazzi grew, their vision expanded too: 'For so many years, Mattiazzi was not known; we produced a lot for other brands,' says Cristina Salvati, Mattiazzi's Global Sales and Marketing Director. 'Eventually, we decided we wanted to have our own collection and work with designers ourselves.'

Thus, in 2009, the company invited designer Nitzan Cohen to conceive a collection specifically for Mattiazzi—and they haven't looked back since.

Cohen then also became Mattiazzi's first Artistic Director and soon brought Florian Lambl on board as Co-Artistic Director (who was then the sole Artistic Director from 2015–2018). In this position, they invited Sam Hecht and Kim Colin of the London-based studio Industrial Facility to design a collection. The duo created the now-iconic BRANCA chair and produced it with a CNC milling machine, using the technology in an entirely new, pioneering way for the time; BRANCA's release in 2010 put Mattiazzi on the map as a company that could not only traverse but also shatter the traditional boundaries between handcrafted and mechanically produced wooden pieces. Or, as designer Jonathan Olivares has said, 'Mattiazzi disproves the modern myth that mechanized manufacturing is not a craft.'

In the years that followed BRANCA's release, Cohen and Lambl went on to invite some of the world's most prolific designers, including Ronan and Erwan Bouroullec, Jasper Morrison, Leon Ramsmeier, and Konstantin Grcic, to create collections. This group have since become Mattiazzi's core designers, with many of them developing multiple collections; the designers the company works with, as Salvati says, 'are part of the family.'

Since starting to produce furnishings under its own name, Mattiazzi has released more than 25 collections, ranging from chairs to tables to stools to benches and lounge seats, designed by over 10 of today's most renowned designers. Beyond furniture, the company—under Hecht and Colin's interim role as Artistic Directors (2018–2021)—also collaborated with younger designers to release a number of solid-wood objects, including a small box, a bowl, and a wine rack. And in 2021, Grcic took over from the duo as Mattiazzi's Artistic Director, also bringing Florian Böhm and Annahita Kamali on board to help develop the brand's visual identity and communication.

'Anything that has to do with wood is something that we are willing to explore within the Mattiazzi family,' Salvati continues.

Be it a chair or a vessel, the guiding principle that unites all Mattiazzi products is that of ethical and high-quality wood processing, from the sourcing of the raw material to the energy needed for production to their commitment to the craft. Specifically, nearly all of Mattiazzi's wood is sourced from within 200 kilometers; the factory—which, since the late 1980s, has been located in San Giovanni, one of the three villages that comprise the chair triangle—runs almost exclusively on power generated by solar panels that were installed in 2010; and a biomass heater recycles waste energy that is used to heat the factory in the winter. Moreover, every product is produced with as little waste as possible, and before air from the factory is released into the atmosphere it goes through a filter that significantly decreases its CO2 emissions.

Looking simultaneously towards the past and the future, Mattiazzi will continue to develop its collaborations with established and emerging contemporary designers while maintaining its roots in the heritage of craftsmanship. State-of-the-art machinery and environmentally friendly, energy-efficient infrastructures will always be paired with passion and traditional techniques—for, as Salvati notes, 'Mattiazzi would not exist without our people's expertise, their care to details, their understanding of the materials. Our products would not exist without our people's hands.'

MC THE MATTIAZZI COLLECTION

| | |
|-------|--|
| MC 22 | FILO Ronan & Erwan Bouroullec |
| MC 21 | LEVA Foster + Partners |
| MC 20 | CUGINO Konstantin Grcic |
| MC 19 | FRONDA Sam Hecht & Kim Colin |
| MC 18 | ZAMPA Jasper Morrison |
| MC 16 | FORCINA Leon Ransmeier |
| MC 15 | QUINDICI Ronan & Erwan Bouroullec |
| MC 14 | PRIMO Konstantin Grcic |
| MC 13 | FACILE Lambi Homburger & Meyer |
| MC 12 | TRONCO Sam Hecht & Kim Colin |
| MC 10 | CLERICI Konstantin Grcic |
| MC 9 | UNCINO Ronan & Erwan Bouroullec |
| MC 8 | CHIARO Leon Ransmeier |
| MC 7 | RADICE Sam Hecht & Kim Colin |
| MC 6 | FIONDA Jasper Morrison |
| MC 5 | SOLO Studio Nitzan Cohen |
| MC 4 | MEDICI Konstantin Grcic |
| MC 3 | OSSO Ronan & Erwan Bouroullec |
| MC 2 | BRANCA Sam Hecht & Kim Colin |
| MC 1 | HE SAID / SHE SAID Studio Nitzan Cohen |



FILO
black on beech,
black rope



FILO
yellow on beech,
yellow rope

FILO Ronan & Erwan Bouroullec



FILO
green on beech,
green rope



FILO CHAIR

· Beech frame

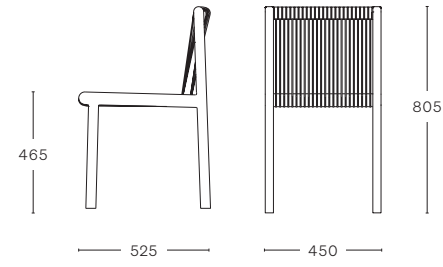

MATERIALS

FRAME
Beech



Black oiled
Grey oiled
RAL 7015
Yellow oiled
RAL 1003
Green oiled
RAL 6008

SEAT AND BACK
Rope

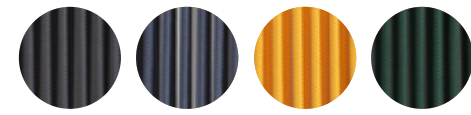

Black
Grey
Yellow
Green



REF. #0420
Photography: LICHT Gallery Showroom



REF. #0326
Photography: Jori Lallo



REF. #0339
Architecture: Flooat Inc. Photography: Tomooki Kengaku



LEVA
black on ash

LEVA Foster + Partners



LEVA
grey on ash



LEVA
ash natural,
leather seat upholstery

LEVA ARMCHAIR

- Ash frame
- Ash frame with non removable upholstery:
 - Kvadrat Basel
 - Kvadrat Steelcut Trio
 - Sørensens Envy Black
 - Sørensens Pure Nature

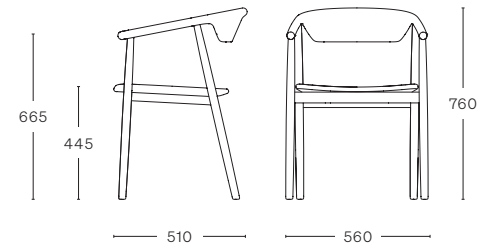

MATERIALS

FRAME

Ash



Natural



Black
RAL 9005



Red
RAL 2002

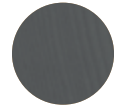

Grey
NCS 4000

UPHOLSTERY

Kvadrat Fabric

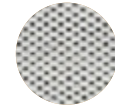

Basel
121

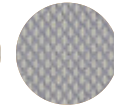

Steelcut Trio
3/105

Sørensens leather



Pure nature
20805



Envy black
20321



REF. #0418

Architecture: Case-Real Photography: Daisuke Shima



REF. #0307

Architecture: Borland Architecture Photography: Jack Level



CUGINO
black on oak

CUGINO
oak natural

CUGINO Konstantin Grcic

CUGINO STOOL:

· Oak frame

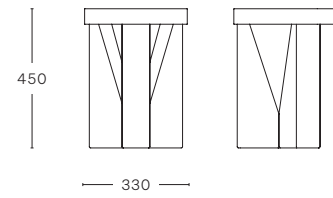

MATERIALS

FRAME
Oak



Natural

Black
RAL 9005



REF. #0282

Architecture: Flooat Inc. Photography: Tomooki Kengaku

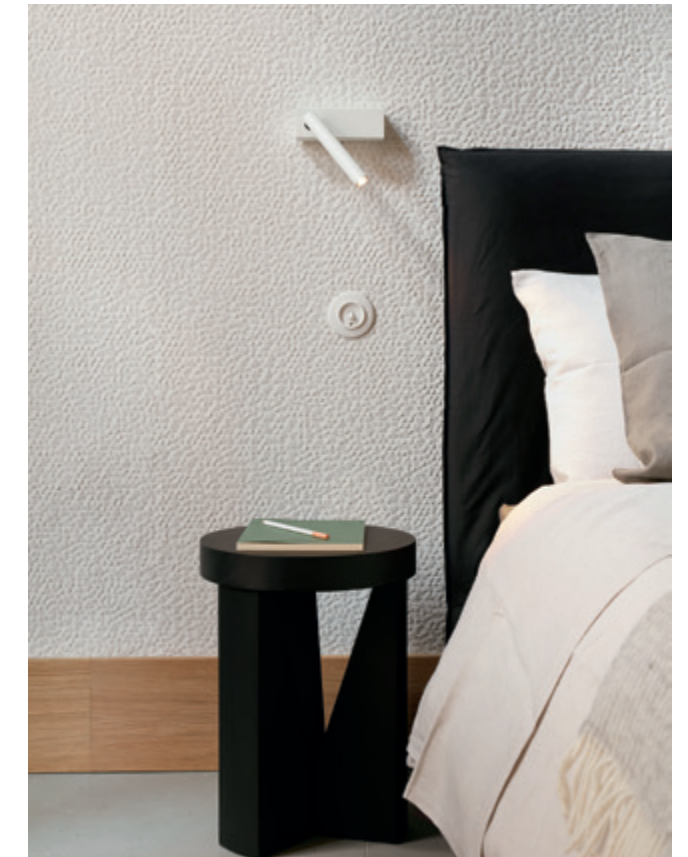

REF. #0290

Photography: De Pasquale & Maffini



REF. #0283

Architecture: Flooat Inc. Photography: Bouillon



FRONDA STOOL
black on pine frame,
fabric seat upholstery

FRONDA CHAIR
pine natural frame,
fabric seat upholstery



FRONDA STOOL
 grey on pine frame,
 silver coated steel seat

FRONDA STOOL
 black on pine frame,
 black coated steel seat

FRONDA CHAIR
 pine natural frame,
 copper coated steel seat

FRONDA CHAIR
 grey on pine frame,
 silver coated steel seat





FRONDA STOOL
pine natural frame,
black coated steel seat



FRONDA TABLE
pine natural frame,
black Fenix NTM® top

FRONDA CHAIR

- Natural pine frame with black or green steel seat
- Black pine frame with black steel seat
- Natural pine frame with silver or copper steel seat
- Grey pine frame with silver steel seat
- Pine frame with non removable upholstery: - Kvadrat Planum

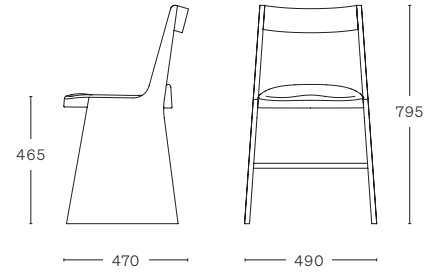

FRONDA LOW STOOL

- Natural pine frame with black or green steel seat
- Black pine frame with black steel seat
- Natural pine frame with silver or copper steel seat
- Grey pine frame with silver steel seat
- Pine frame with non removable upholstery: - Kvadrat Planum

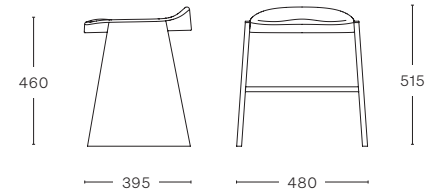

FRONDA TABLE

- Sizes:
- 2000 x 900 mm
 - 2400 x 900 mm with 4 x EU socket outlet

- Natural pine frame with FENIX NTM® top

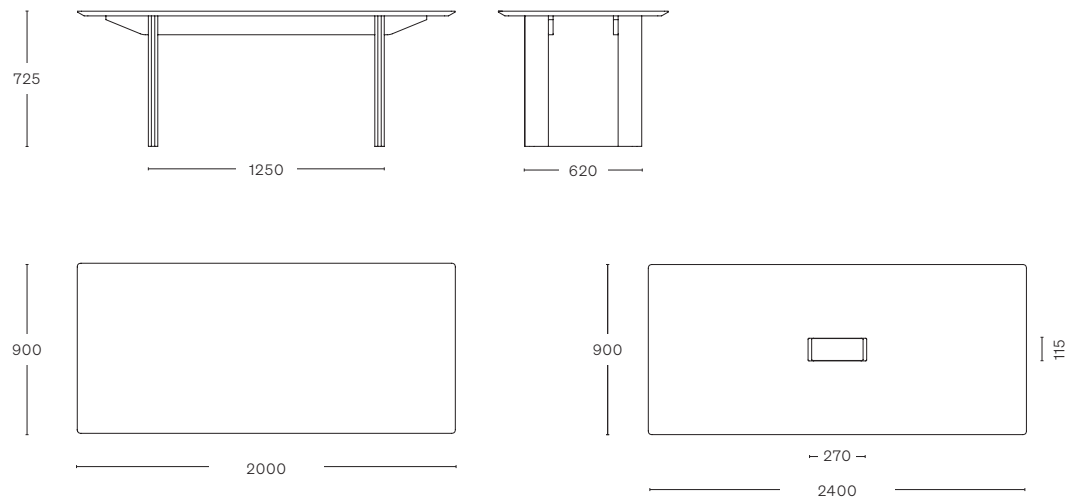

- Bachmann Connect Line 4 x socket outlet

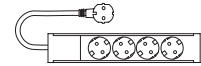

MATERIALS

FRAME Pine

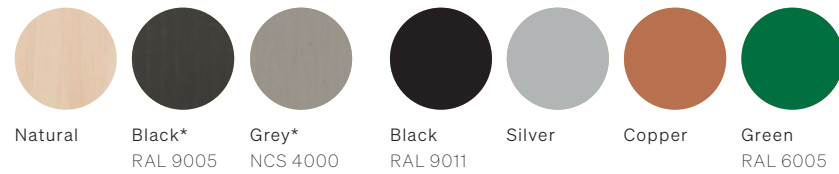

SEAT Steel

UPHOLSTERY Kvadrat Planum

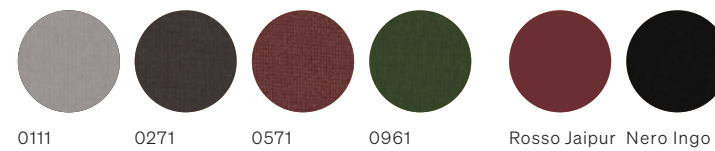

TABLE TOP FENIX NTM® top



*not for Fronda Table



REF. #0336

Architecture: DWA Design Studio Photography: Alberto Strada



REF. #0292

Architecture: VSHD Design Photography: Oculis Project



REF. #0338

Photography: Jules Cebo



ZAMPA CHAIR
ash natural



ZAMPA CHAIR
black on ash

ZAMPA Jasper Morrison



ZAMPA CHAIR
ash natural

ZAMPA CHAIR
red on ash

ZAMPA LOW STOOL
red on ash





ZAMPA LOW STOOL
neon blue on ash

ZAMPA COUNTER STOOL
neon blue on ash

ZAMPA LOW STOOL
ash natural

ZAMPA COUNTER STOOL
ash natural

ZAMPA BAR STOOL
walnut stained on ash

ZAMPA COUNTER STOOL
ash natural

ZAMPA CHAIR

· Ash frame

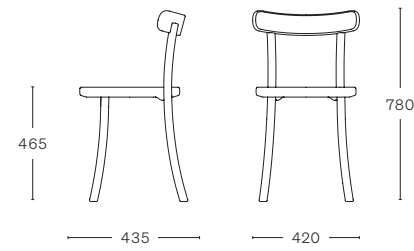

ZAMPA LOW STOOL

· Ash frame

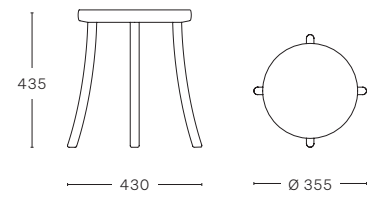

ZAMPA COUNTER STOOL

· Ash frame

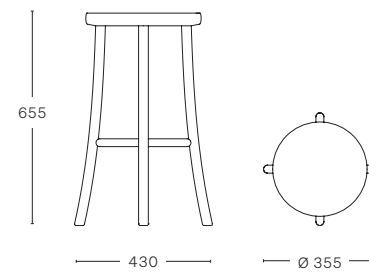

ZAMPA BAR STOOL

· Ash frame

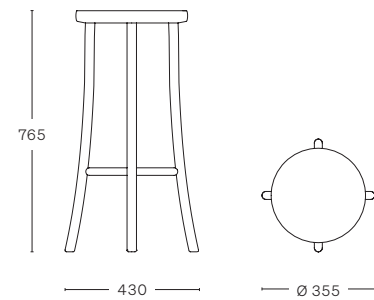

MATERIALS

FRAME
Ash



REF. #0392
Architecture: Studio 103 & McCormack Photography: Emily Bartlett



REF. #0308
Architecture: Studio Framer Photography: Yongjun Choi

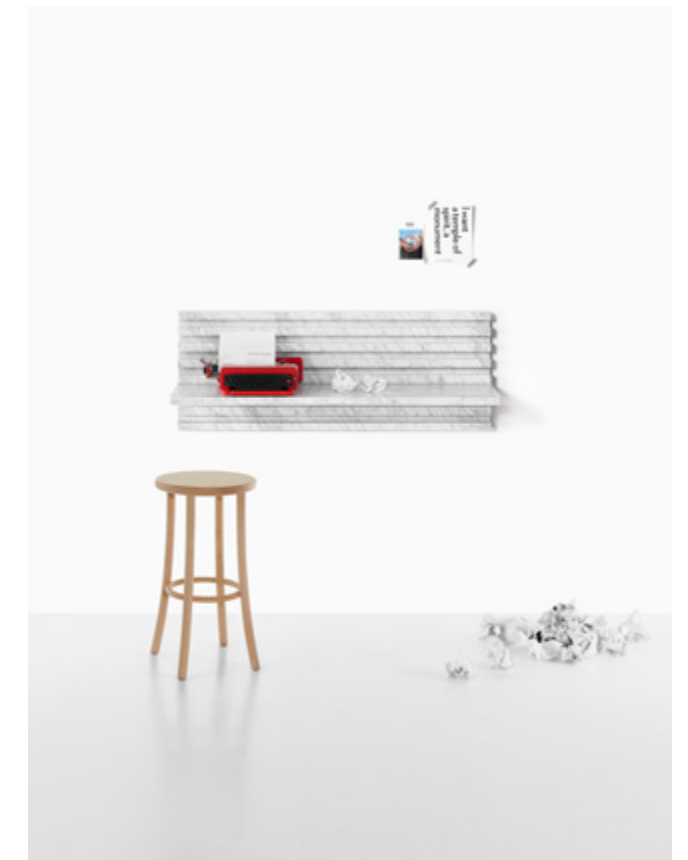

REF. #0393
Photography: Alberto Strada



FORCINA TABLE
black coated stainless
steel frame,
black on ash tabletop

FORCINA CHAIR
black coated stainless
steel frame,
black on ash seat and
backrest

FORCINA Leon Ransmeier



FORCINA ARMCHAIR
black coated stainless
steel frame,
black on ash seat and
backrest

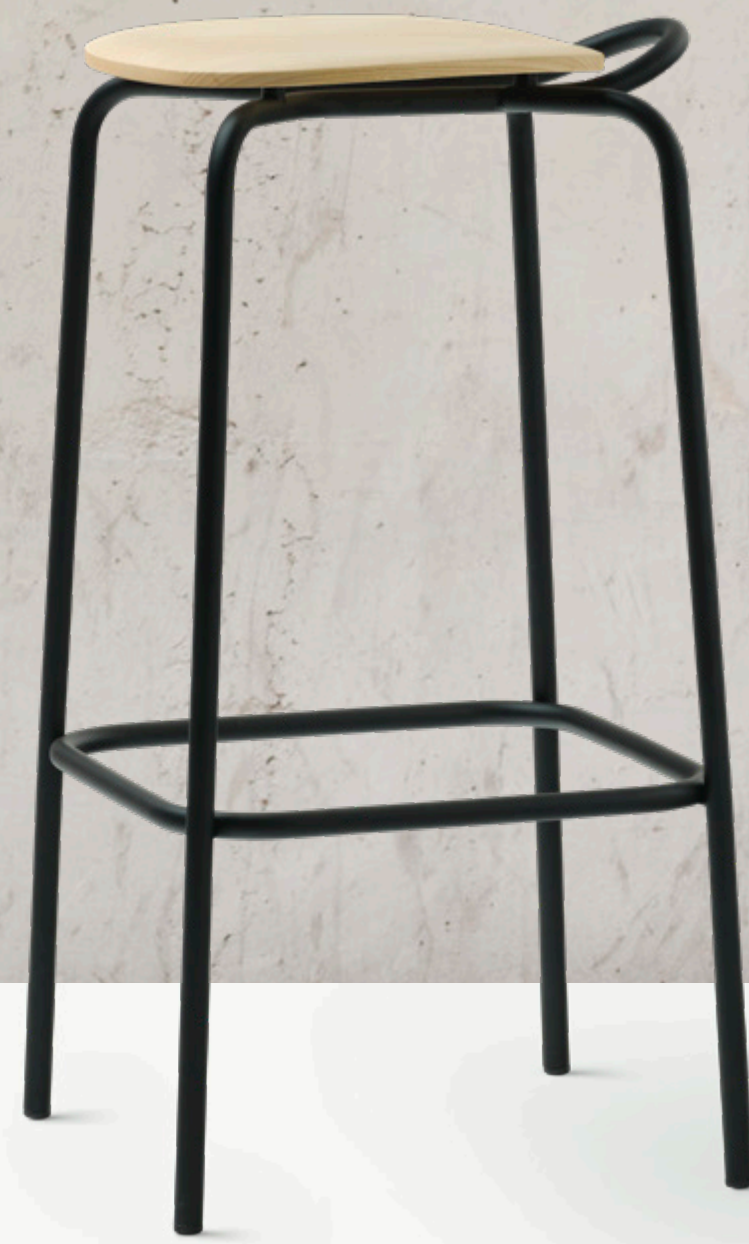

FORCINA BAR STOOL
black coated stainless
steel frame,
natural ash seat

FORCINA CHAIR

- Black Stainless Steel frame
- Ash
- Oak
- Robinia (for outdoor use)
- Brushed Stainless Steel frame
- Ash
- Oak
- Robinia (for outdoor use)

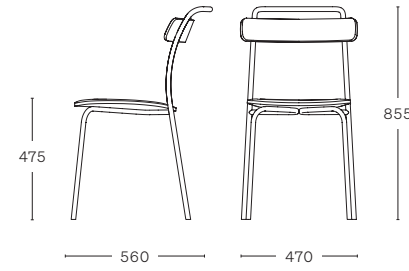

Stackable x3 

FORCINA ARMCHAIR

- Black Stainless Steel frame
- Ash
- Oak
- Robinia (for outdoor use)
- Brushed Stainless Steel frame
- Ash
- Oak
- Robinia (for outdoor use)

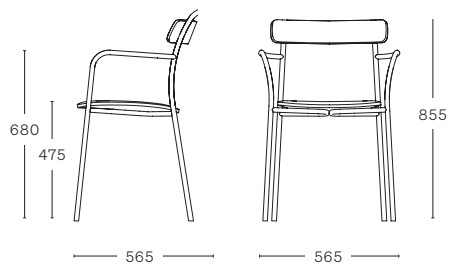

Stackable x3 

FORCINA LOW STOOL

- Black Stainless Steel frame
- Ash
- Oak
- Robinia (for outdoor use)
- Brushed Stainless Steel frame
- Ash
- Oak
- Robinia (for outdoor use)

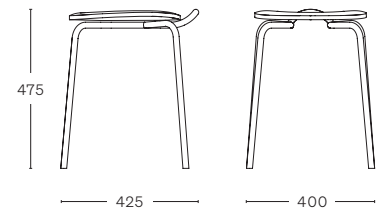

Stackable x3 

FORCINA BAR STOOL

- Black Stainless Steel frame
- Ash
- Oak
- Robinia (for outdoor use)
- Brushed Stainless Steel frame
- Ash
- Oak
- Robinia (for outdoor use)

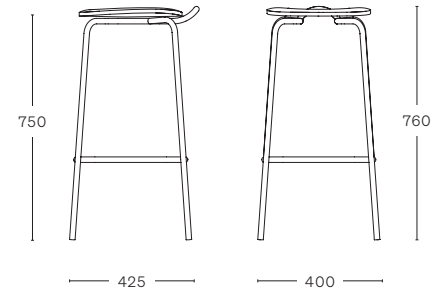

FORCINA TABLE

- Sizes:
- 700 x 700 mm
 - Ø 800 mm (round)

- Black Stainless Steel frame
- Ash
- Oak
- Robinia (for outdoor use)
- Brushed Stainless Steel frame
- Ash
- Oak
- Robinia (for outdoor use)

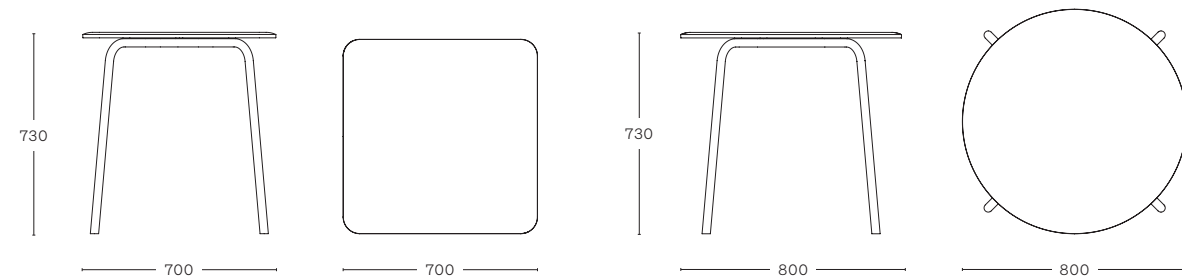

MATERIALS

SEAT AND BACK

Ash



Natural



Black
RAL 9005

Oak



Natural

Robinia



Oiled

FRAME

Stainless Steel frame



Black



Brushed



REF. #0264

Photography: Gerhardt Kellermann



REF. #0314

Architecture: Marco Zito & Artico Fracassi Photography: Marco Cappelletti



QUINDICI LOUNGE
ash natural, leather upholstery

QUINDICI Ronan & Erwan Bouroullec



QUINDICI CHAISE LONGUE
grey on ash, fabric upholstery

QUINDICI LOUNGE UPHOLSTERY

- Ash frame with removable upholstery:
- Kvadrat Divina 3
- Dani Lord Leather

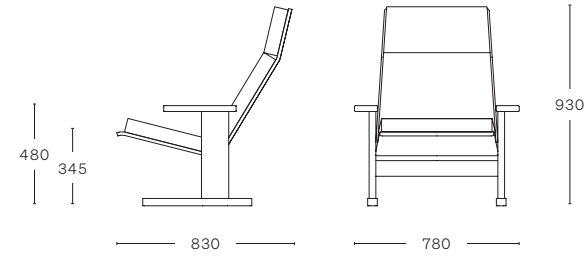

QUINDICI CHAISE LONGUE UPHOLSTERY

- Ash frame with removable upholstery:
- Kvadrat Divina 3
- Dani Lord Leather

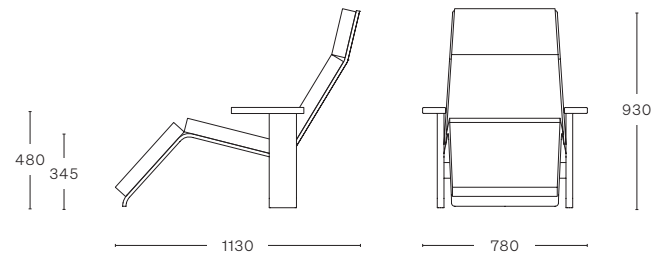

MATERIALS

FRAME

Ash



Natural Grey Black
RAL 7046 RAL 9005

UPHOLSTERY

Kvadrat Divina 3 Dani Lord Leather



191

9300



REF. #0222

Photography: Valentina Sommariva



REF. #0420

Photography: LICHT Gallery Showroom



PRIMO CHAIR
oak natural,
leather seat upholstery

PRIMO Konstantin Grcic



PRIMO CHAIR
black on beech

PRIMO CHAIR
gold on beech



PRIMO BAR STOOL
beech natural,
brushed aluminum footrest



PRIMO CHAIR

- Beech frame
- Gold beech frame
- Oak frame with non removable upholstery:
 - Dani Acquario Leather
 - Sweet Leather

Stackable x3 

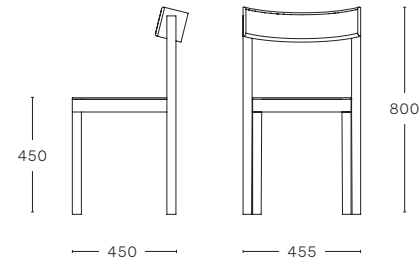

PRIMO COUNTER STOOL

- Beech frame
- Oak frame with non removable upholstery:
 - Dani Acquario Leather
 - Sweet Leather

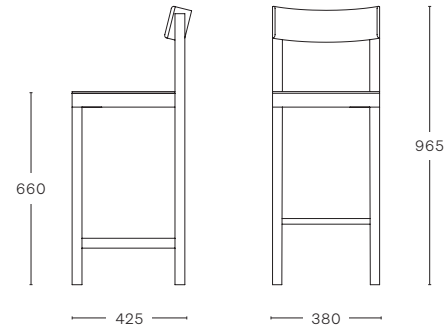

PRIMO BAR STOOL

- Beech frame
- Oak frame with non removable upholstery:
 - Dani Acquario Leather
 - Sweet Leather

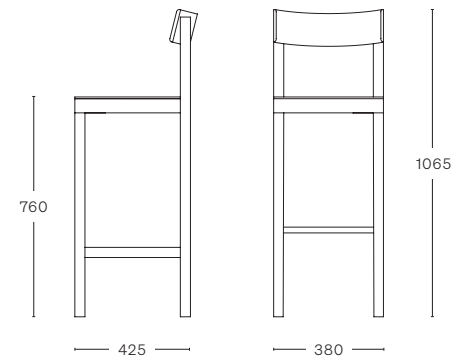

PRIMO TABLE

- Sizes:
- 900 x 900 mm
 - 1800 x 900 mm

- Natural oak frame
- Oak veneered top
- FENIX NTM® top

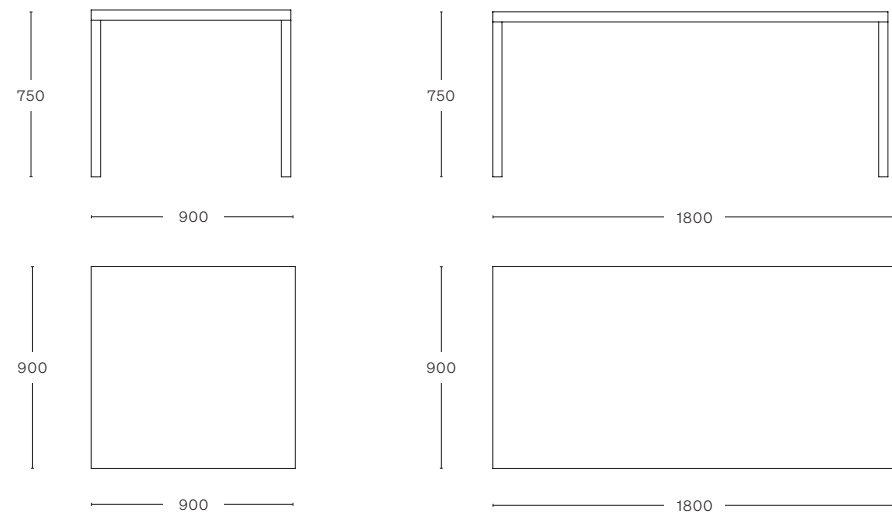

MATERIALS



*not for Primo Counter & Bar Stool



REF. #0341

Architecture: Ffloat Inc. Photography: Tomooki Kengaku



REF. #0247

Architecture: Maximilian Gottwald Photography: Maximilian Gottwald

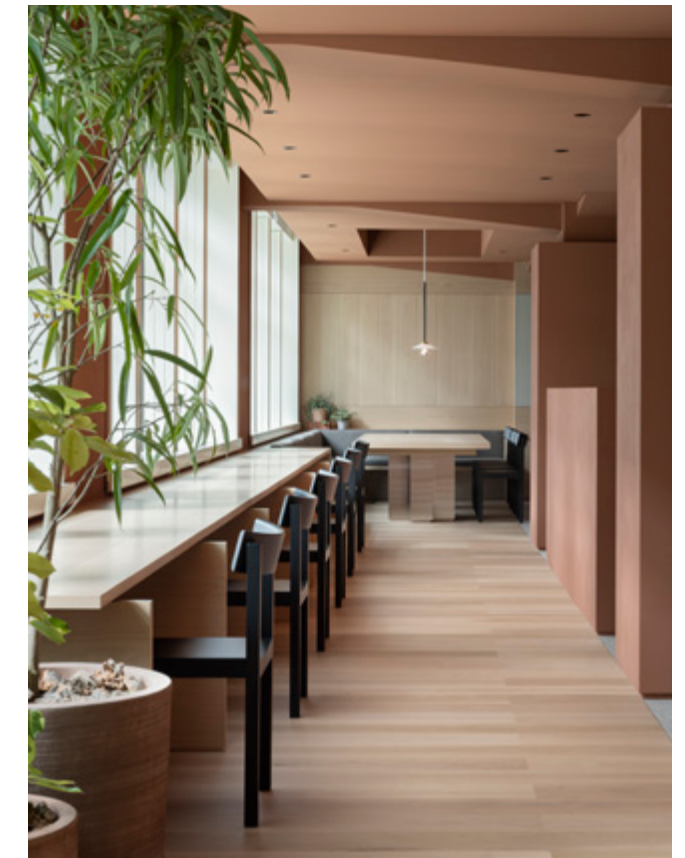

REF. #0339

Architecture: Ffloat Inc. Photography: Tomooki Kengaku



FACILE BENCH
black on ash

FACILE TABLE
black on ash

FACILE Lambl Homburger & Meyer

FACILE BENCH

Sizes:
 - 1180 x 350 mm
 - 1800 x 350 mm

- Natural Ash frame
- Black Ash frame

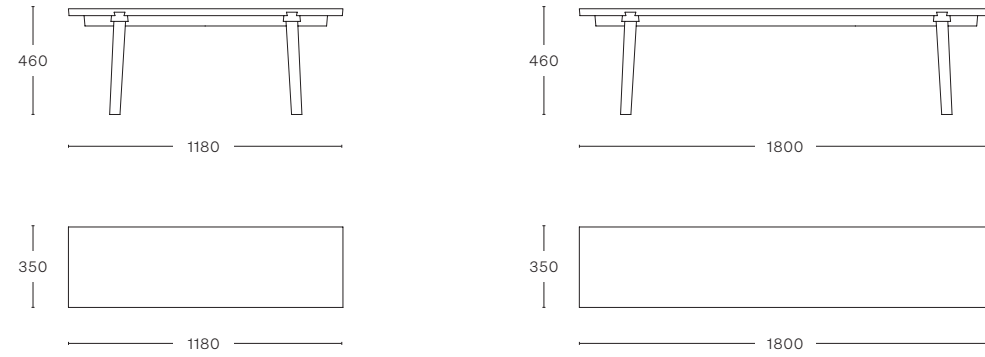

FACILE TABLE

Sizes:
 - 1800 x 900 mm
 - 2400 x 900 mm

- Natural Ash frame
- Black Ash frame

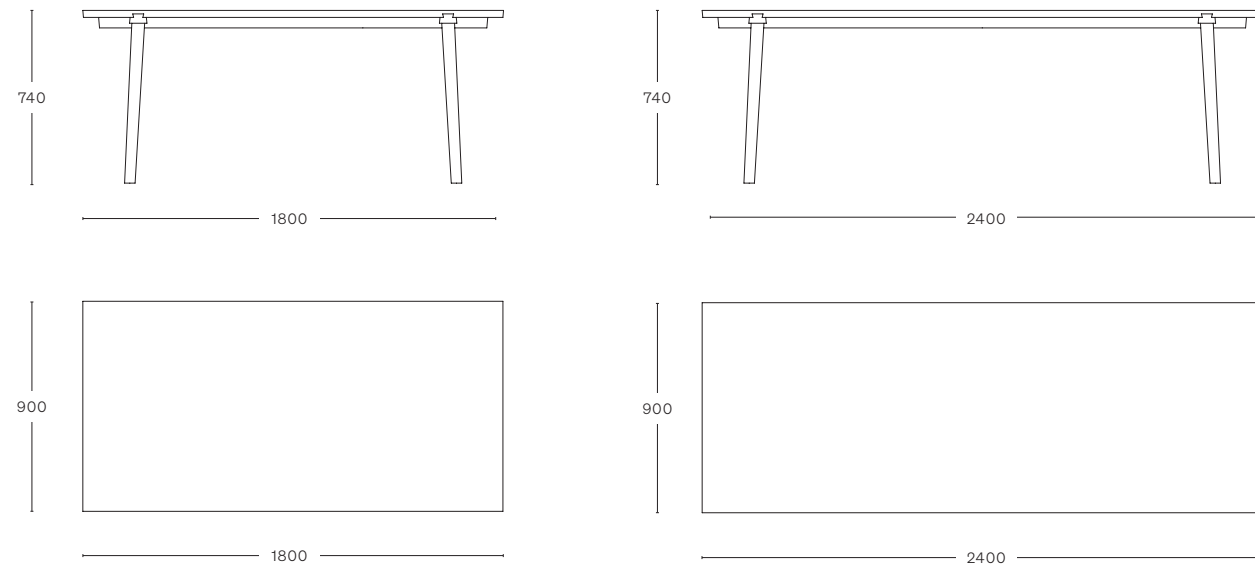

MATERIALS

FRAME
 Ash

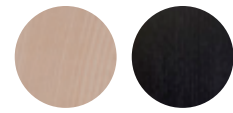

Natural Black
 RAL 9005



REF. #0210
 Architecture: Marie Deroudilhe Photography: Julie Ansiau



REF. #0252
 Photography: Frau Boutique



TRONCO CHAIR
ash natural,
fabric upholstery

TRONCO Sam Hecht & Kim Colin



TRONCO CHAIR
walnut stained on ash





TRONCO CHAIR
green on ash,
fabric upholstery

TRONCO CHAIR
white on ash

TRONCO CHAIR

- Ash frame
- Ash frame with non removable upholstery:
- Rohi Topia

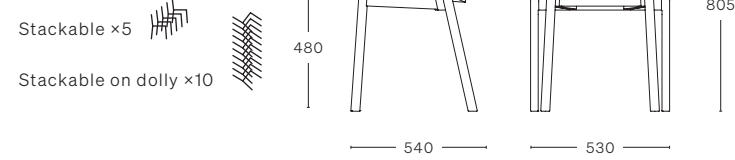

TRONCO TABLE

- Ash frame

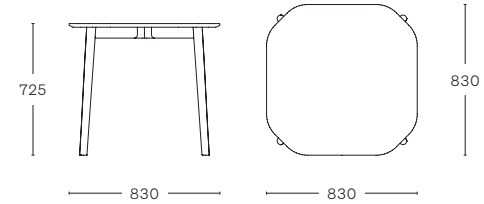

TRONCO CONNECTOR

- Plastic Connector

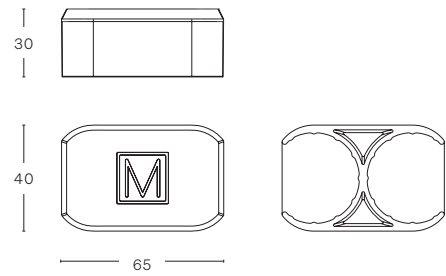

- Row Connector
- Plastic PA6 + 30% Glass Fiber

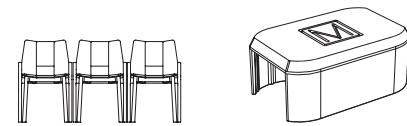

TRONCO DOLLY

- Powder coated metal

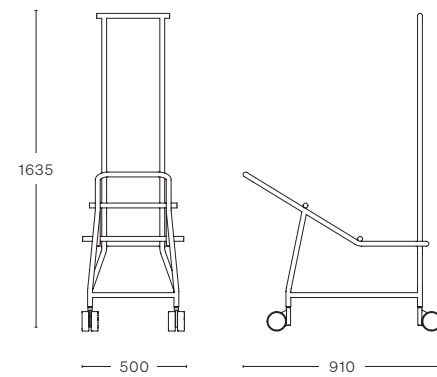

MATERIALS

FRAME

Ash



Natural Black RAL 9005 White RAL 9003 Walnut Stained Chestnut Stained Olived* Red* RAL 2002 Green* RAL 6007

DOLLY FRAME

Powder Coated Metal



White RAL 9003 Black RAL 9005

PLASTIC CONNECTOR

Mat Plastic

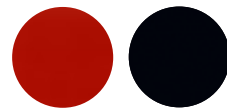

Red RAL 3020 Black RAL 8022

UPHOLSTERY

Rohi Topia

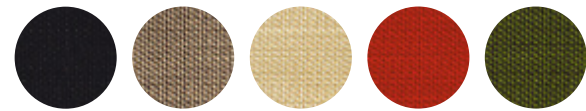

Ebony Walnut Moon Chili Palm

*not for Tronco Table



REF. #0183

Architecture: Sundukovy Sisters Photography: Dmitry Tsyrenshchikov



REF. #0293

Architecture: Sayes Studio Photography: Samuel Hartnett



REF. #0019

Architecture: Antonio Guacci Photography: Gerhardt Kellermann



REF. #0338

Photography: Zoe Liao



CLERICI LOUNGE
grey on ash



CLERICI LOUNGE
oak natural



CLERICI TABLE
ash natural



CLERICI 2 SEATER
oak natural,
leather seat upholstery

CLERICI LOUNGE

Sizes:
- One Seat
- 2 Seater

· Ash frame
· Oak frame

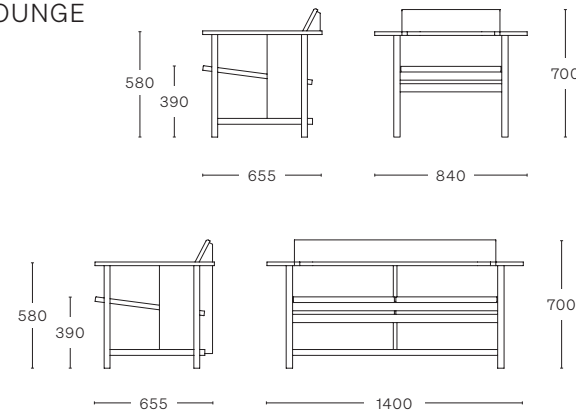

CLERICI LOUNGE

UPHOLSTERY

Sizes:
- One Seat
- 2 Seater

· Oak frame with non removable upholstery:
- Dani Acquario
Leather

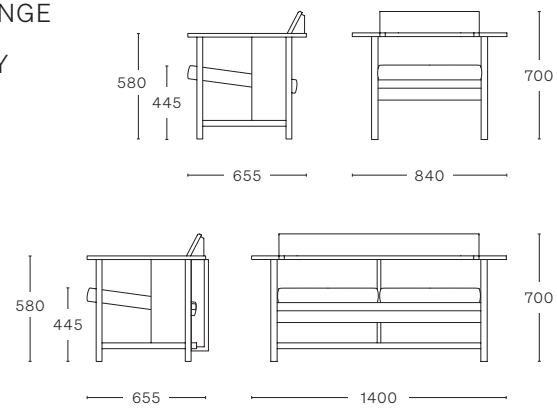

CLERICI BENCH

Size:
- 3 Seater

· Ash frame

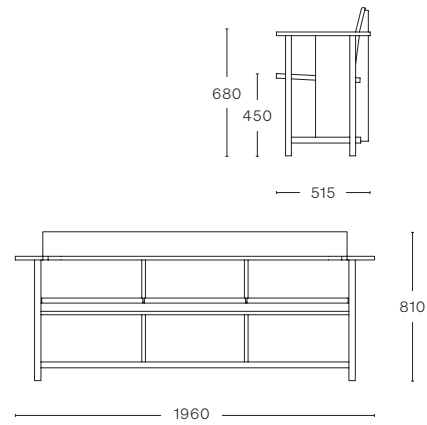

CLERICI TABLE
(OUTDOOR)

Size:
- 1110 x 555 m

· Iroko (for outdoor use)

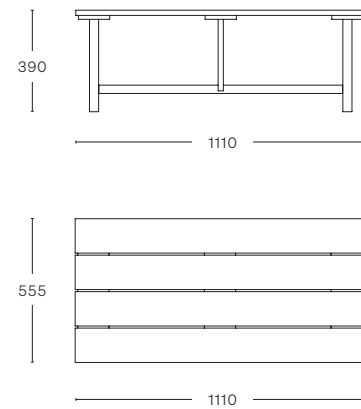

CLERICI TABLE

Sizes:
- 2400 x 1000 mm
- 3000 x 1000 mm

· Natural ash

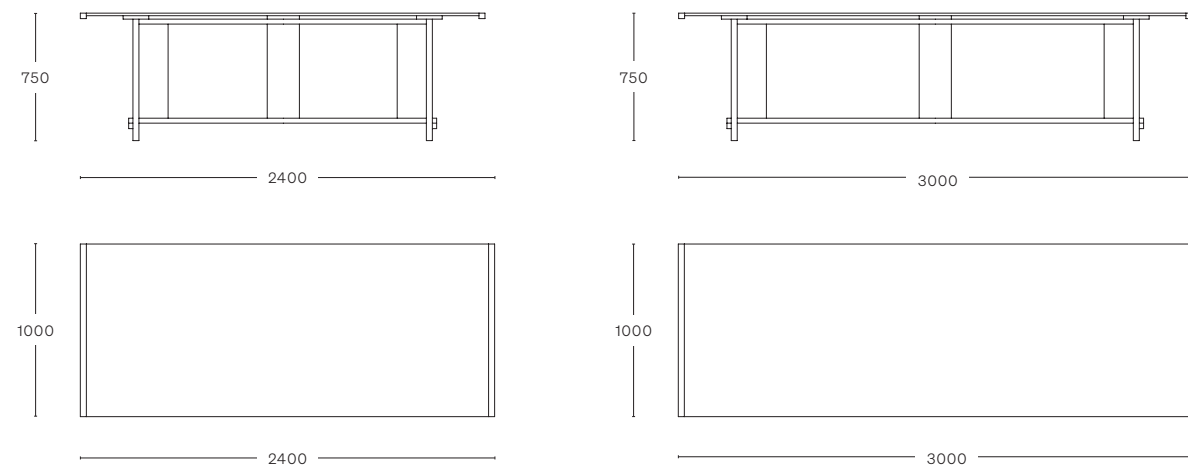

MATERIALS

FRAME

Ash



Natural Grey Red
RAL 7031 RAL 2002

Oak



Natural

Iroko



Oiled

UPHOLSTERY

Dani Acquario
Leather



Cuio Marrone



REF. #0248

Architecture: Aspekt Office Photography: Rasmus Dengsø



REF. #0220

Architecture: Kollekted By Photography: Inger Marie Grini



REF. #0237

Architecture: Note Design Studio Photography: Michael Sinclair



UNCINO VERSION C
black coated steel frame,
black on ash seat and
backrest



UNCINO VERSION A
black coated steel frame,
black on ash seat and backrest

UNCINO VERSION B
black coated steel frame,
black on ash seat and backrest

UNCINO Ronan & Erwan Bouroullec



UNCINO VERSION B
black coated steel frame,
ash natural seat and backrest



UNCINO BAR STOOL
ash natural,
black coated steel footrest
and base

UNCINO VERSION A

· Ash

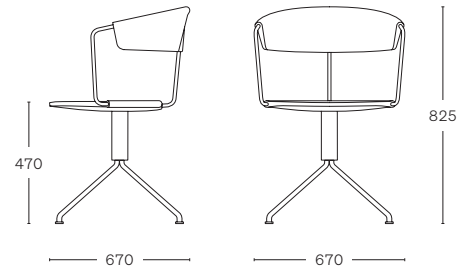

UNCINO VERSION B

· Oak

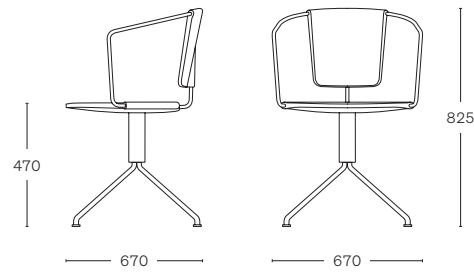

UNCINO VERSION C

· Ash

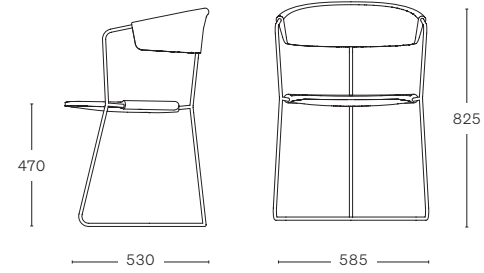

UNCINO BAR STOOL

· Ash

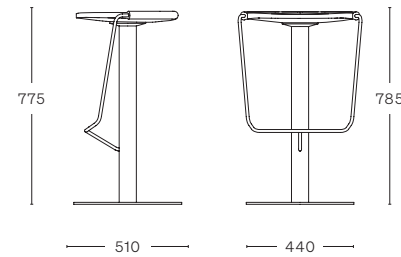

MATERIALS

SEAT AND BACK

Ash

Oak

FRAME

Metal Frame



Natural

Black
RAL 9005

Natural

Black



REF. #0199

Architecture: Winwood McKenzie Photography: Ben Hosking



REF. #0339

Architecture: Flooat Inc. Photography: Tomoki Kengaku



REF. #0333

Photography: Gerhardt Kellermann

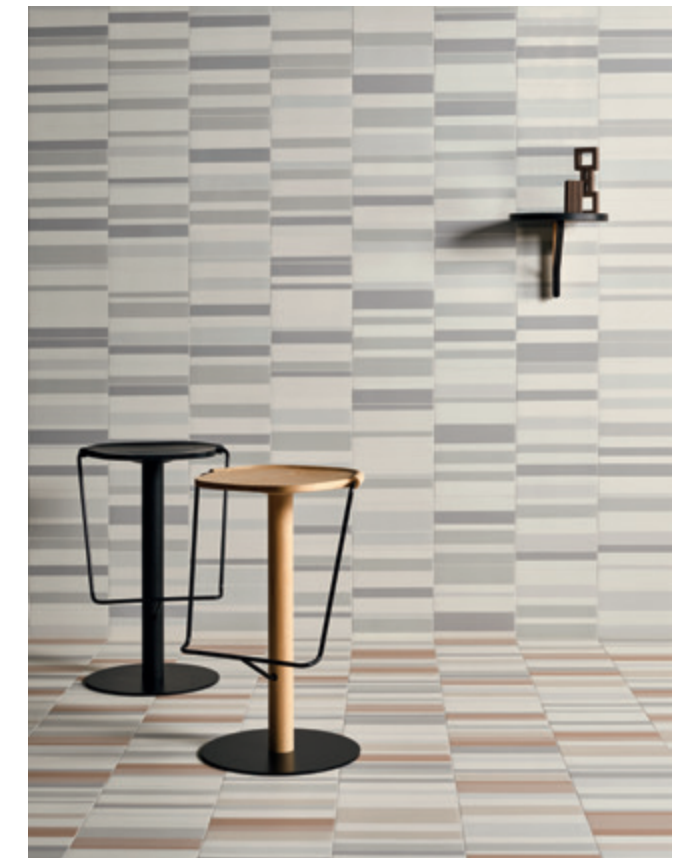

REF. #0178

Photography: Gerhardt Kellermann



CHIARO ARMCHAIR
ash natural,
fabric seat upholstery



CHIARO Leon Ransmeier



CHIARO CHAIR
ash natural



CHIARO BAR STOOL
dark red on ash,
brushed stainless steel footrest



CHIARO CHAIR

- Ash frame
- Ash frame with non removable upholstery: - Rohi Novum
- Oak frame
- Oak frame with non removable upholstery: - Rohi Novum

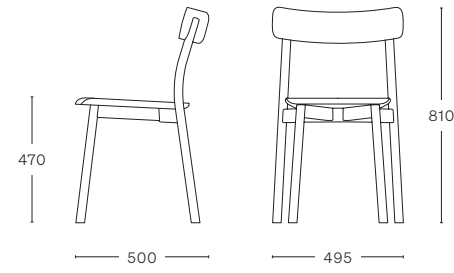

Stackable x3

CHIARO ARMCHAIR

- Ash frame
- Ash frame with non removable upholstery: - Rohi Novum
- Oak frame
- Oak frame with non removable upholstery: - Rohi Novum

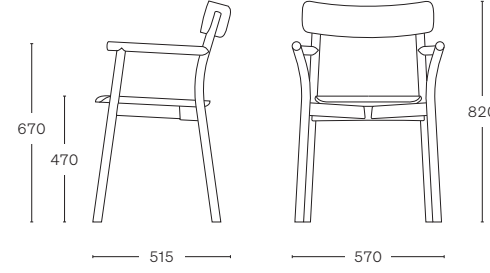

Stackable x3

CHIARO COUNTER STOOL

- Ash frame

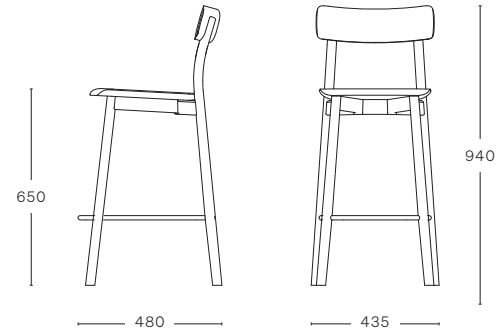

CHIARO BAR STOOL

- Ash frame

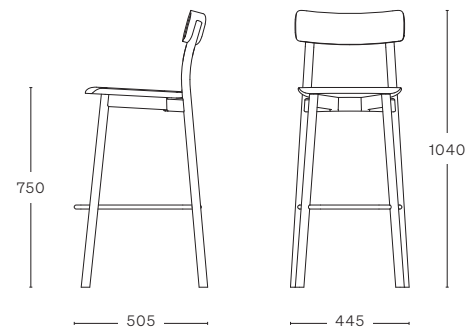

MATERIALS

FRAME

Ash



Oak



Natural

FOOTREST

Metal



Brushed

UPHOLSTERY

Rohi Novum

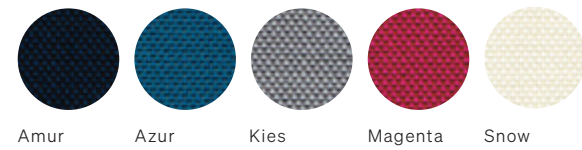

Amur

Azur

Kies

Magenta

Snow



REF. #0391

Architecture: Matt Crawford Architects Photography: Dion Robeson



REF. #0210

Architecture: Marie Derouilhe Photography: Julie Ansiau



REF. #0272

Architecture: akkurat bauatelier AG Photography: Damian Poffet



RADICE CHAIR
ash natural



RADICE Sam Hecht & Kim Colin



RADICE COUNTER STOOL
black on ash



RADICE COUNTER STOOL
red on ash,
fabric seat upholstery



RADICE CHAIR

- Ash frame
- Removable upholstery:
 - Rohi Novum
 - Sweet Leather

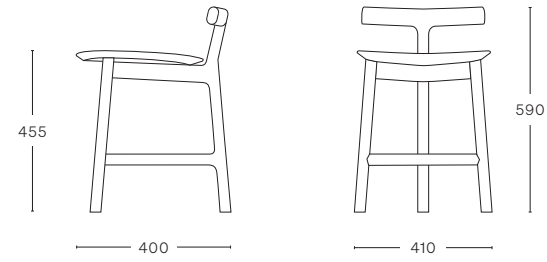

RADICE COUNTER STOOL

- Ash frame
- Removable upholstery:
 - Rohi Novum
 - Sweet Leather

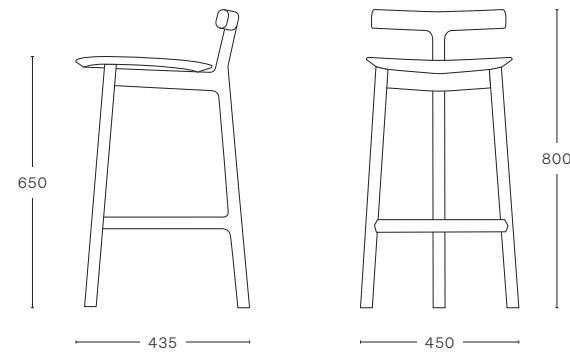

MATERIALS

FRAME
Ash



UPHOLSTERY
Rohi Novum

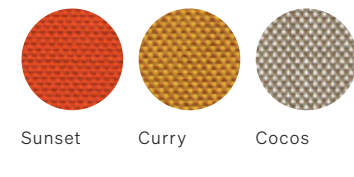

Sweet Leather



REF. #0296
Architecture: Note Design Studio Photography: Joakim Johansson



REF. #0294
Architecture: XForma Photography: Alexander Volodin



REF. #0084
Architecture: Ester Bruzkus Architekten Photography: Jens Bösenberg



REF. #0278
Architecture: Note Design Studio Photography: Simon Bevan



FIONDA
ash natural,
fabric upholstery



FIONDA Jasper Morrison

FIONDA SIDE CHAIR

- Black ash frame with removable canvas covers:
- Natural Canvas
- Orange Canvas

Nesting x5 

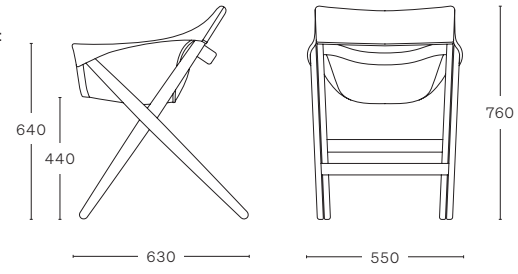

MATERIALS

FRAME
Ash

UPHOLSTERY
Canvas

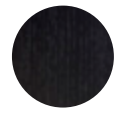

Black
RAL 9005

Natural

Orange



REF. #0058

Architecture: Arent&Pyke Photography: James Whineray



SOLO CHAIR
ash natural



SOLO CHAIR
neon blue on ash

SOLO TABLE
neon blue on ash



SOLO Studio Nitzan Cohen



SOLO BAR STOOL
oak natural,
grey coated steel footrest



SOLO LOW STOOL
turquoise on ash,
white coated steel footrest



SOLO CHAIR
black/blue on ash,
leather seat upholstery



SOLO CHAIR
ash natural

SOLO TABLE
ash natural

SOLO CHAIR

- Ash frame
- Ash frame with non removable upholstery:
 - Sweet Leather
- Oak frame
- Oak frame with non removable upholstery:
 - Sweet Leather

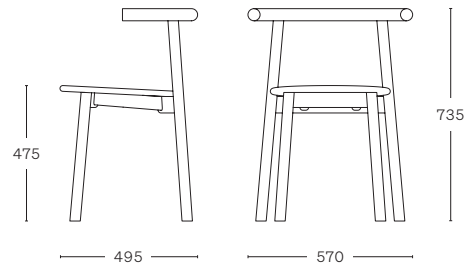

Stackable x3 

SOLO LOW STOOL

- Ash frame
- Oak frame

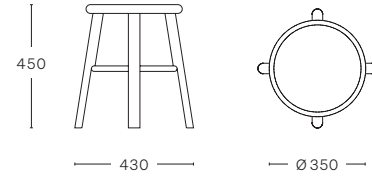

SOLO COUNTER STOOL

- Ash frame
- Oak frame
- Bicolour on oak

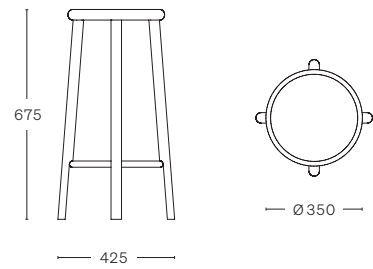

SOLO BAR STOOL

- Ash frame
- Oak frame
- Bicolour on oak

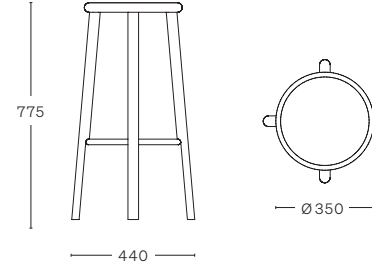

SOLO TABLE

- Sizes:
- 650 x 650 mm
 - Ø 650 mm (round)

- Ash frame
- Oak frame

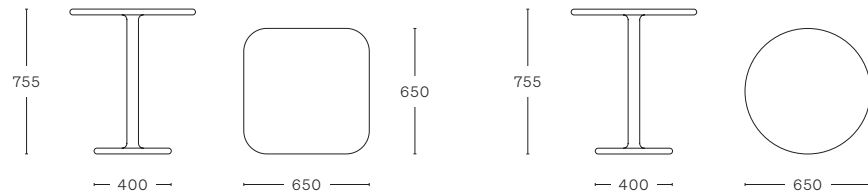

MATERIALS

FRAME

- Ash
- Natural
 - Black/Blue RAL 5004
 - White RAL 9003
 - Neon Blue RAL 5013
 - Turquoise NCS 2010
 - Dark Red RAL 3009

Oak

- Natural
- Black/Blue & Natural

FOOTREST

- Metal
- White RAL 9003
 - Black/Blue RAL 5004
 - Grey* RAL 7004
 - Red* RAL 3009

UPHOLSTERY

Sweet Leather

- Black/Blue 559
- Grey 566
- Red 534

*not for Solo Low Stool



REF. #0250

Architecture: Aires Mateus Photography: Maria Masià & Rui Cardoso

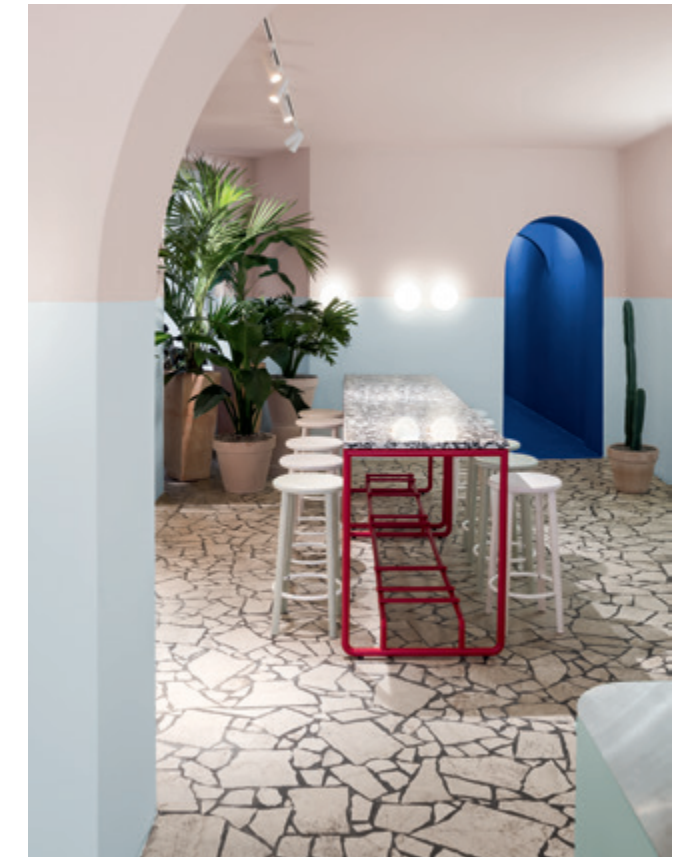

REF. #0173

Architecture: Ester Bruzkus Architekten Photography: Jens Bösenberg



REF. #0340

Architecture: Rezen Studio Photography: Jack Lovel



REF. #0321

Architecture: Aires Mateus Photography: Francisco Nogueira

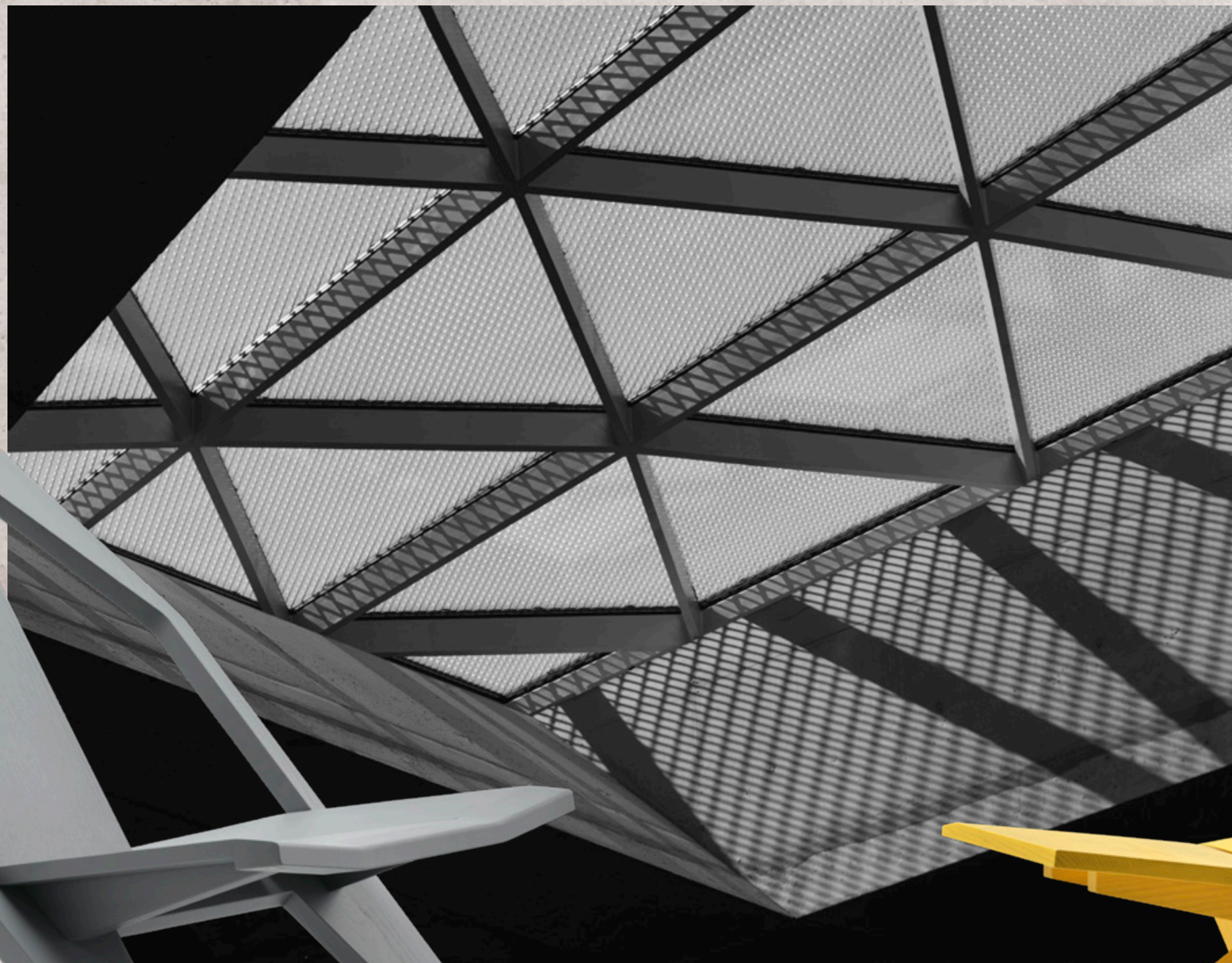

MEDICI LOUNGE
grey on ash



MEDICI STOOL
yellow on ash

MEDICI Konstantin Grcic



MEDICI STOOL
red on ash

MEDICI LOUNGE
red on ash

MEDICI TABLE
red on ash



MEDICI TABLE
red on ash





MEDICI LOUNGE
ash natural



MEDICI LOUNGE
thermo-treated ash

MEDICI LOUNGE

- Ash frame
- Thermo ash frame oiled (for outdoor use)

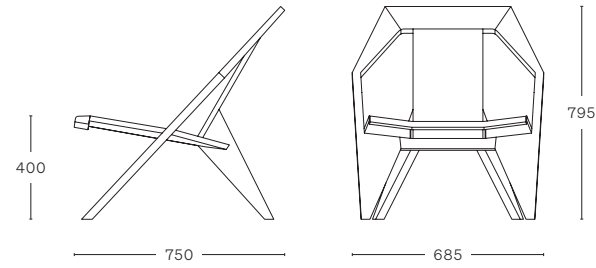

MEDICI TABLE

- Ash frame
- Thermo ash frame oiled (for outdoor use)
- Walnut frame

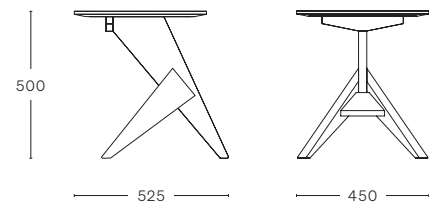

MEDICI STOOL

- Ash frame
- Thermo ash frame oiled (for outdoor use)
- Walnut frame

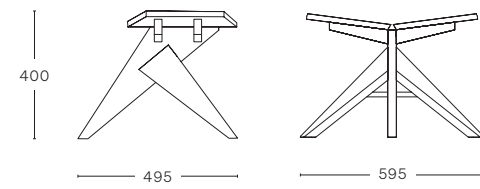

MATERIALS

FRAME
Ash

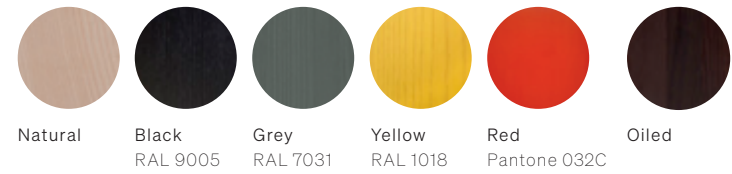

REF. #0291

Architecture: Jump Studios & Antipod Studio Photography: Relja Ivanic

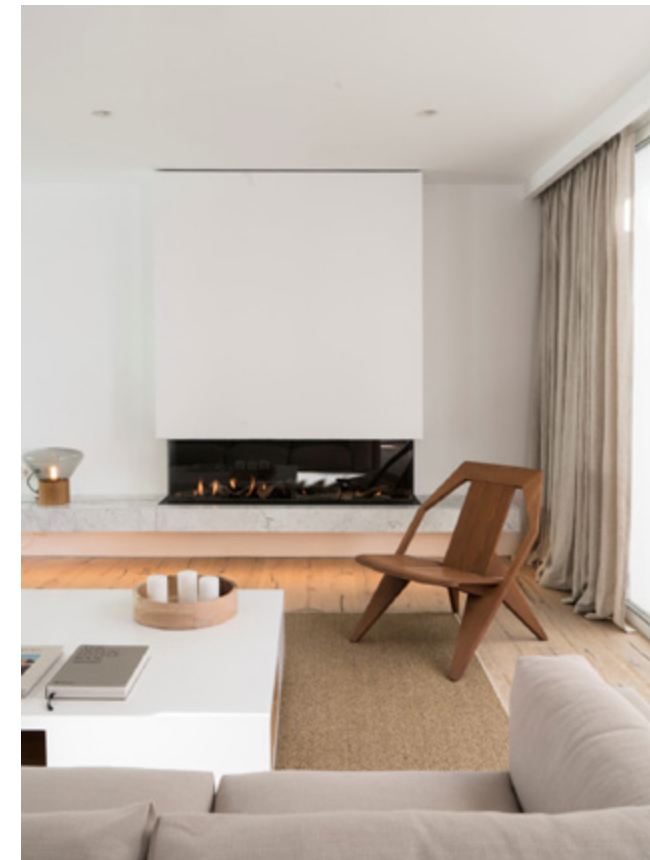

REF. #0255

Architecture: NEGRE Studio Photography: Mauricio Fuertes



REF. #0357

Architecture: Marie Deroudilhe Photography: Eric Laignel



OSSO LOW STOOL
grey on ash



OSSO CHAIR
pink on ash

OSSO Ronan & Erwan Bouroullec



OSSO CHAIR
oak natural



OSSO TABLE
grey on ash





OSSO COUNTER STOOL
white on ash



OSSO LOW STOOL
green on ash

OSSO CHAIR

- Ash frame
- Oak frame

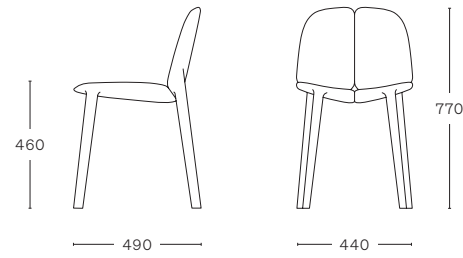

OSSO LOW STOOL

- Ash frame

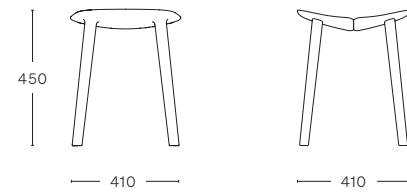

OSSO COUNTER STOOL

- Ash frame
- Oak frame

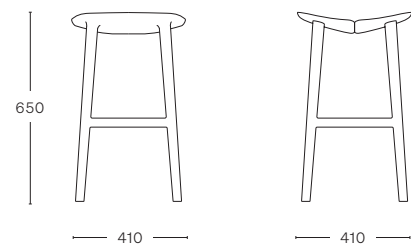

OSSO BAR STOOL

- Ash frame
- Oak frame

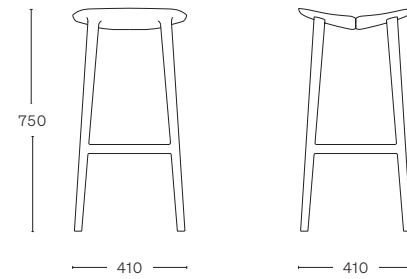

OSSO TABLE

- Sizes:
- 1300 x 800 mm
 - Ø 650 mm (round)

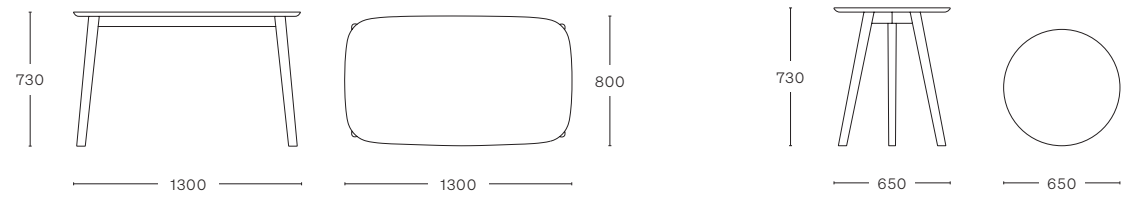

- Ash frame
- Oak frame

- Size:
- 650 x 650 mm

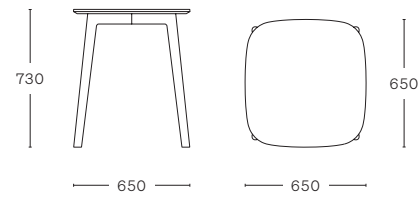

- Ash frame

MATERIALS

FRAME

Ash



Natural Black RAL 9005 White RAL 9003 Grey RAL 7031 Blue RAL 5008 Pink WCP 157 Green RAL 6003 Natural



REF. #0329

Architecture: Studio Anna Kunst Photography: Rowfotografie

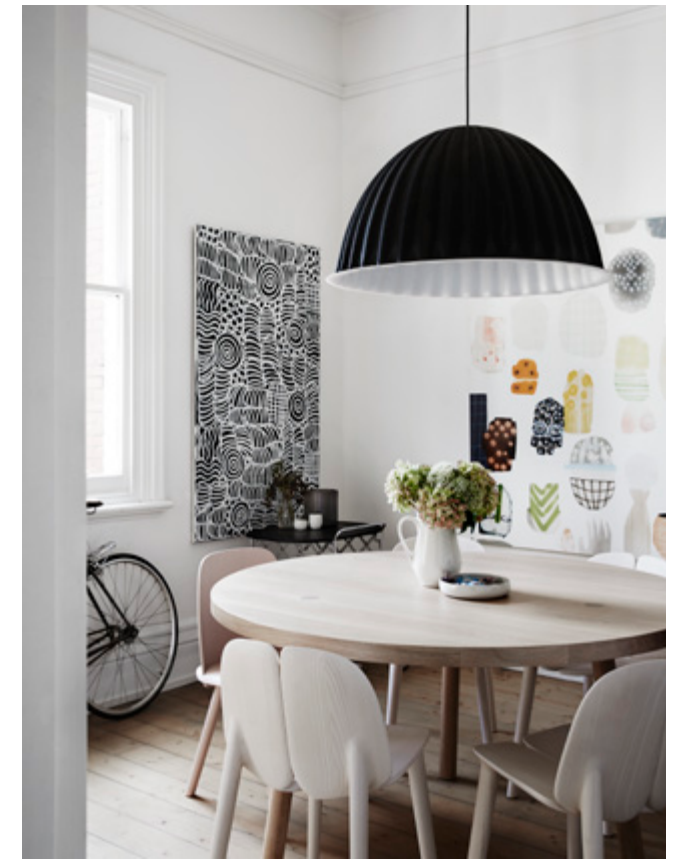

REF. #0201

Architecture: Carole Whiting Photography: Sharyn Cairns



REF. #0374

Architecture: Hecker Guthrie Photography: Shannon McGrath



BRANCA CHAIR
green on ash

BRANCA TABLE
ash natural

BRANCA CHAIR
green on ash



BRANCA Sam Hecht & Kim Colin



BRANCA CHAIR
black on ash,
fabric seat upholstery



BRANCA COUNTER STOOL
ash natural,
white coated steel footrest



BRANCA CHAIR

- Ash frame
- Removable upholstery:
 - Abi Nord Wool
 - Rohi Novum



BRANCA COUNTER STOOL

- Ash frame
- Removable upholstery:
 - Rohi Novum

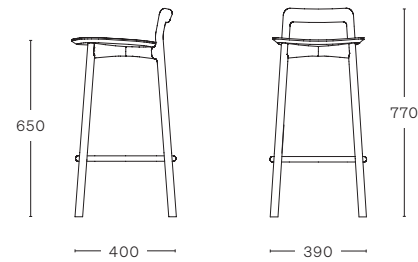

BRANCA BAR STOOL

- Ash frame
- Removable upholstery:
 - Rohi Novum

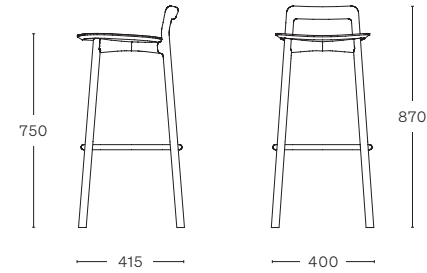

BRANCA TABLE

- Size:
- 1500 x 1100 mm

- Ash frame
- MDF top white lacquered
- Ash wood top

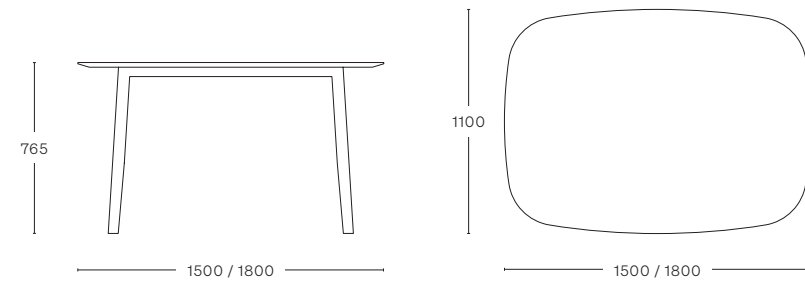

- Size:
- 1800 x 1100 mm

- Ash frame
- MDF top white lacquered

MATERIALS

FRAME Ash

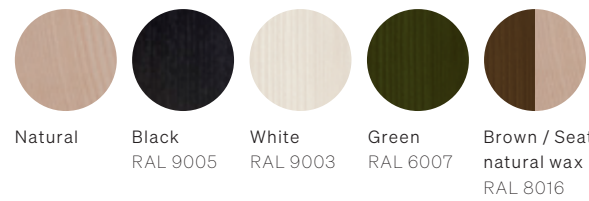

FOOTREST Metal



UPHOLSTERY Abi Nord Wool

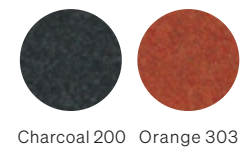

Rohi Novum



*not for Branca Counter and Bar Stool



REF. #0310

Architecture: VPS Architetti Photography: Studio Vetroblu



REF. #0210

Architecture: Marie Derouilhe Photography: Julie Ansiau



REF. #0188

Architecture: Clara Walter & Raphael Danke Photography: JUNI



SHE SAID LOWIDE
black on ash

SHE SAID CHAIR
black on ash,
fabric seat upholstery

HE SAID / SHE SAID STUDIO NITZAN COHEN



SHE SAID BAR STOOL
neon blue on ash



HE SAID
ash natural

HE SAID CHAIR

- Ash frame
- Ash frame with non removable upholstery:
- Rohi Topia

· Stackable x2 

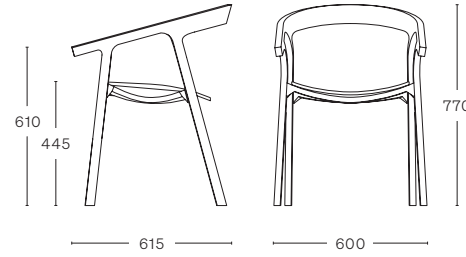

SHE SAID CHAIR

- Ash frame
- Ash frame with non removable upholstery:
- Rohi Topia

· Stackable x2 

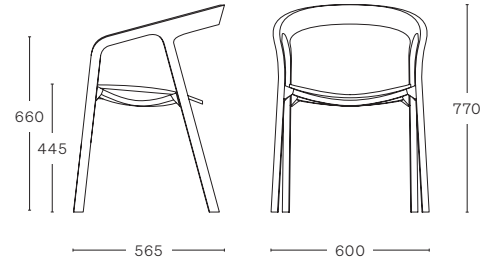

SHE SAID LOWIDE

- Ash frame

Stackable x2 

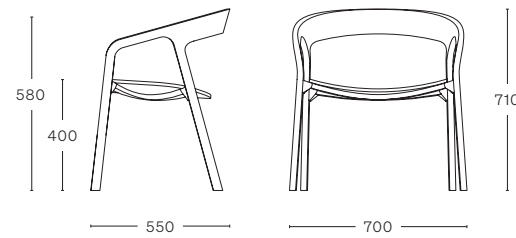

SHE SAID COUNTER STOOL

- Ash frame
- Ash frame with non removable upholstery:
- Rohi Topia

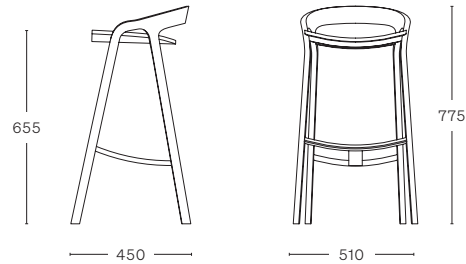

SHE SAID BAR STOOL

- Ash frame
- Ash frame with non removable upholstery:
- Rohi Topia

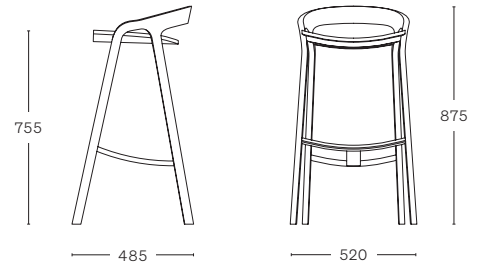

MATERIALS

FRAME

Ash

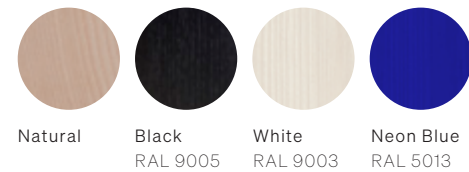

UPHOLSTERY

Rohi Topia



REF. #0271
Architecture: FLIP Studio Photography: Yunpu Cai



REF. #0301
Architecture: DOMANI Photography: Vincent Wu



REF. #0285
Architecture: Leeton Pointon Photography: Lisa Cohen

RONAN AND ERWAN BOUROULLEC

Ronan (born in 1971) and Erwan Bouroullec (born in 1976) are brothers and designers based in Paris. They have been working together for more than twenty years bonded by diligence and challenged by their distinct personalities. Their studio is based in Paris and their team numbers around six people.

In 1997, they were spotted by Cappellini, giving them their first industrial design projects. They began working with the Galerie kreò in 2000 and had their first solo show there in 2001. Issey Miyake then hired them to design the boutique to house his new collection A-Poc. They met then Rolf Fehlbaum, President of Vitra, and worked on a new office system entitled Joyn. Since then, they have gone on to work with Artek, Alessi, Axor Hansgrohe, Cappellini, Established & Sons, Flos, Hay, Kettal, Kvadrat, Kartell, Glas Italia, Ligne Roset, Magis, iittala, Mattiazzi, Mutina, Nani Marquina, Samsung and Vitra.

Their work has covered many field ranging from the design of small objects as jewellery to spatial arrangements and architecture, from craftsmanship to industrial scale, from drawings to videos and photography. The designers also maintain an experimental activity with Gallery kreò, which is also essential to the development of their work.

STUDIO NITZAN COHEN

Prof. Nitzan Cohen (born in 1973) is Dean of the Faculty of Design and Art of the Free University of Bozen-Bolzano. After graduating from the design academy in Eindhoven (2002), he was part of the Siemens-Mobile Designlab think-tank, Germany/China. Thereafter, he started working with Konstantin Grcic (2003–2007) as a designer and project leader on a wide range of projects for international companies and institutions.

After this extensive period Cohen established his own design practice, a multi-disciplinary design studio (Studio Nitzan Cohen) engaged in projects ranging from industrial products, furniture and spaces to art-direction and design consultancy; collaborating with a wide range of partners, from large international corporations to small artisanal workshops, cultural institutes and Museums. Combining design work with design research and design didactic, Cohen is engaged in design teaching, gives lectures and holds workshops in different international design forums and institutions.

Cohen held a chair for Industrial and System Design at the HBK Saar (Hochschule der Bildenden Künste) in Saarbrücken (2012–14) and a guest professorship at the Master of Arts in Espace et Communication at the HEAD (Haute école d'art et de design) in Geneva (2011–14). As of 2015 Cohen is a full professor for product design at the Faculty of Design and Art of the Free University of Bolzano. His current interests cover the fields of design for sustainable solutions, the future of open source: manufacturing aesthetics and logic. Bio-based sustainable materials and nano technologies.

SAM HECHT & KIM COLIN

London-based studio Industrial Facility was co-founded in 2002 by designers Sam Hecht (born in 1969) and Kim Colin (born in 1961). Their approach reflects both a thoughtful consideration of form and a unique understanding of contemporary life, creating beauty out of utility in the products, furniture and exhibitions they design. Hecht, from London, trained as an industrial designer, while Colin, from Los Angeles, trained as an architect; together they have helped clients to produce projects that display an understanding of cultural relevance and commercial success.

Hecht and Colin's desire is to work for industry in a way that improves the things we live with. Not setting out to produce something different but rather something better, they aim to design things that will last, be effective and give satisfaction often beyond what is called for by the product and the client. Industrial Facility is considered as one of the most progressive studios in product, furniture and exhibition design. With a roster of pioneering clients, including Muji, Herman Miller, Emeco, Mattiazzi, Epon and Wästberg, they are regarded for both their philosophical and pragmatic approach.

KONSTANTIN GRIC

Konstantin Grcic (born in 1965) was trained as a cabinet maker at The John Makepeace School for Craftsmen in Wood before studying Design at the Royal College of Art in London. Since setting up his own practice in 1991 he has developed furniture, products and lighting for leading design companies. Today, Konstantin Grcic Design is based in Berlin and is active in several fields ranging from industrial design projects, design editions, exhibition design and collaborations in architecture and fashion.

Among his producers are Artek, Authentics, Cassina, ClassiCon, Flos, Flötotto, Kettal, Laufen, Magis, Mattiazzi, Muji, Mutina, Nespresso, Plank, Serafino Zani and Vitra. From the fashion and lifestyle sector he has worked with Audi, Hugo Boss, Issey Miyake, Louis Vuitton, Prada, Rado and smart/Daimler amongst others.

Grcic has worked with various intuitional clients such as the Venice Architecture Biennial, the Musée des Art Décoratifs (Paris), the Istituto Svizzero (Rome), the Fonds national d'art contemporain (FNAC), the Serpentine Gallery (London), the St. Etienne Design Biennial, the Vitra Design Museum (Weil am Rhein) and the MUDAM (Luxemburg).

Many of his products have won international design awards, such as the Compasso d'Oro and the German Design Award in Gold. The world's most important design museums (including MoMA, New York/Centre Pompidou, Paris/Die Neue Sammlung, Munich) have included his designs in their permanent collections.

In 2009, Grcic has been appointed as Honorary Royal Designer for Industry by the Royal Society for the Encouragement of Arts, Manufactures and Commerce (RSA / UK). Since 2020, Grcic holds a professorship at the Hamburg University of Fine Arts (Hochschule für Bildende Künste) and has been appointed member of the Academy of Arts (Akademie der Künste), Berlin in 2021.

LAMBL / HOMBURGER

Studio Lambl Homburger was the joint design practice of Birgitta Homburger and Florian Lambl from 2006-2018. Since then, the founders have pursued their own projects and continue to shape the industry.

Birgitta Homburger is a creative director, designer, and strategist. With a focus on cultural context and strategic thinking she has built an impressive portfolio of work that spans the international stage, including collaborations with brands such as Mattiazzi, Wästberg, Volkswagen, and Laufen Bathroom. Her contributions to the development of Creative Direction and product design have been recognized through her guest professorships at Kunsthochschule Kassel and several institutions like Universität der Künste in Berlin and the Akademie der Bildenden Künste in Stuttgart. In 2023, her dedication to her craft led her to become the Creative Director and partner of Analog, an innovative glass brand based in Berlin.

Florian Lambl took up his professional experience and founded the brand TYP. As a creative director, he leads TYP in publishing furniture, objects, and editions that showcase his unique design sensibilities.

Lambl Homburger partnered with a variety of clients, from global brands to cultural institutions, to help them create authentic and impactful communication strategies. Their expertise in design and branding enabled them to guide Mattiazzi, to a leading furniture brand and its success.

JASPER MORRISON

Jasper Morrison (born in 1959) is a leading British designer, best known for his work in furniture, lighting, tableware and everyday products. He studied design at Kingston Polytechnic, the Royal College of Art and Berlin's HdK. In 1986 he opened his Office for Design in London, which remains his base. He seeks to design objects that fit seamlessly into everyday surroundings. Among recent projects are the seating types Zampa, APC and Iso-Lounge, the Oplight, Raami tableware, and a mobile phone.

Jasper began by designing objects from ready-made components—as seen in his Handlebar Table (1982)—and selling them himself in small batches. He made his name with the Thinking Man's Chair (1985), Plywood Chair (1988) and the 1144 Handle (1991), pieces which reduced furniture visually to its essential needs. In early exhibitions Reuters News Centre at Documenta 8 (1987) and Some New Items for the Home at the Berlin Design Werkstatt (1988), he proved his inventiveness by creating a powerful atmosphere with just three walls and a small number of objects. Aram and SCP in London, Cappellini in Milan, and FSB in Brakel were the first manufacturers to produce Jasper's designs. He has gone on to design furniture and products for companies such as Vitra, Flos, Emeco, Magis, Maruni, Mattiazzi, Muji and Alessi. Examples include the Hal chair, the Rotary Tray, Glo-ball lighting, Alfi, Air Chair, cutlery and the Glass Family. Over the decades he has honed his expertise in designing objects that are simple and familiar in form yet characterful and refreshing.

Jasper's approach to design was reflected in the exhibition Super Normal, which he organised in Japan in 2006 with the Japanese designer Naoto Fukasawa. This exhibition inspired the opening of the Jasper Morrison Shop beside his London studio in 2009. The Shop sells his designs alongside products from around the world.

Jasper has published several books with Lars Müller Publishers which articulate his sensibility. These include A World Without Words, The Good Life, A Book of Things and Super Normal (with Naoto Fukasawa). He has curated and participated in many exhibitions in Japan and across Europe. His contribution to design has been recognised with membership of the Royal Designers for Industry, the Compasso D'Oro and a CBE.

FOSTER + PARTNERS

Foster + Partners is a global studio for architecture, urbanism and design, rooted in sustainability, which was founded fifty years ago in 1967 by Norman Foster.

Since then, he and the team around him have established an international practice with a worldwide reputation for thoughtful and pioneering design, working as a single studio that is both ethnically and culturally diverse. The studio integrates the skills of architecture with several other disciplines in a collegiate working environment that is similar to a compact university. These diverse skills make us capable of tackling a wide range of projects, particularly those of considerable complexity and scale.

The practice has never drawn a distinction between architecture and industrial design. The point of contact, the thing that you touch, is as important as the broader vision. The industrial design team established in 1980, has developed a wide range of products from door handles to wind turbines; from a fountain pen to the cabin of an executive jet; from a tap to the fit-out of an ocean yacht.

Mike Holland joined Foster + Partners in April 1995. As Head of Industrial Design he leads a team of designers to develop commercial mass manufactured products, lighting, furniture, building products and transportation for clients across the globe. He also works closely with the architectural studios designing bespoke solutions for a diverse range of projects around the world. He designed bespoke furniture and interiors for the Maggie's Centre in Manchester, The National Bank of Kuwait, Apple Park in Cupertino and Bloomberg in London.

LEON RANSMEIER

Leon Ransmeier (born in 1979) is the founder and director of Ransmeier Inc., a New York-based design office. A graduate from the Rhode Island School of Design, his work has been published internationally and is included in the permanent collections at the San Francisco Museum of Modern Art, The Corning Museum of Glass, and the RISD Museum. Clients include 2016/Arita, HAY, Herman Miller, Japan Creative, Maharam, Mattiazzi and Wright 21.

Ransmeier's designs have been exhibited at Cooper Hewitt Smithsonian Design Museum (New York), Friedman Benda Gallery (New York), Plusdesign Gallery (Milan, Italy), Swiss Institute (New York), and at SFMOMA (California). He is an editor of the historical survey Herman Miller, A Way of Living released by Phaidon Press in 2019. His writings on design, art, and architecture have been published in Apartamento, Disegno, and PIN-UP.

CREATIVE DIRECTION

Konstantin Grcic with
Florian Böhm, Annahita Kamali
(Studio AKFB)

CATALOGUE DESIGN

Studio AKFB

PHOTOGRAPHY

Joe Fletcher (p. 10-11)
Einar Aslaksen (p. 12; 42-43; 77; 106-107; 112-113; 130-131; 136-137)
Mikael Olsson (p. 18-19; 26-27; 55; 56-57; 124-125)
Maxime Delvaux (p. 22-23; 48-49; 50-51; 94; 122)
Fabian Frinzel (p. 28-29; 38-39; 66-67; 75; 82-83; 104-105)
Miro Zagnoli (p. 30-31; 36-37)
Ståle Eriksen (p. 34-35; 70-71)
HIL Architects (p. 58)
Alberto Strada (p. 62; 90-91)
Ralph Feiner (p. 88-89)
Gerhardt Kellermann (p. 96-97; 107; 108-109; 114; 117; 120; 128-129; 130)

PHOTOGRAPHY PRODUCTS

Studio AKFB

PRINTING

Poligrafiche San Marco

MATTIAZZI SRL

Via Sottorive, 19 /2
33048 S. Giovanni al Natisone (UD) Italy
T + 39 0432 75 74 74 · F + 39 0432 75 65 72
info@mattiazzi.eu · www.mattiazzi.eu

© 2023 Mattiazzi Srl. All rights reserved. No part of this publication may be reproduced, stored in a retrieval system or transmitted in any form or by any means, electronic, mechanical, photocopying, recording or otherwise, without the permission of Mattiazzi Srl. Mattiazzi reserves the right to introduce any changes to its own models without prior notice.



MATTIAZZI
ITALY